

TOP VIEW

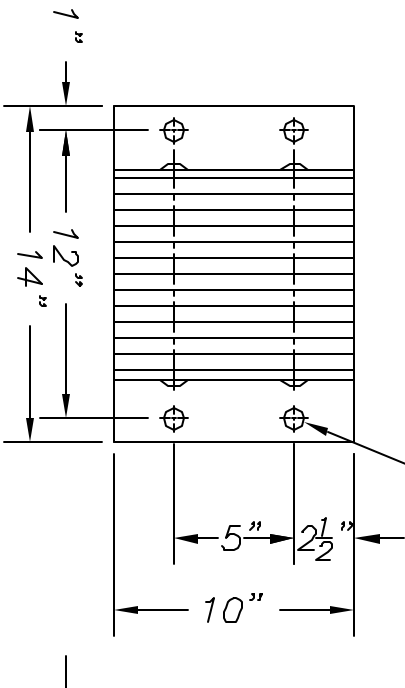

FRONT VIEW

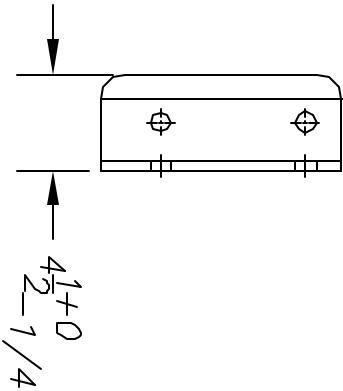

RIGHT SIDE VIEW

NOTES:
 UNIT SHOWN IS "ANGLES BOTH SIDES" (B410-12)
 STANDARD "P1" CONFIGURATION (B410-12/P1)
 IS ANGLE ONE SIDE, FLAT ON OTHER,
 FOR WELDING TO DOCK FACE ON ONE SIDE
 AND ANCHORING TO DOCK FACE ON THE OTHER.
 "P2" CONFIGURATION (B410-12/P2)
 IS FLAT BOTH SIDES FOR WELDING
 TO DOCK FACE ON BOTH SIDES.
 ALL TOLERANCES ARE $\pm 1/8"$
 UNLESS OTHERWISE NOTED.

ESTIMATED GROSS SHIPPING WEIGHT = 25 lbs.

THIS DRAWING AND THE DESIGN SHOWN ARE THE PROPERTY OF TMI INCORPORATED. REPRODUCTION OR USE OF THIS DRAWING FOR ANY PURPOSE OTHER THAN THAT SPECIFIED SHALL BE VIEWED AS INFRINGEMENT AND BE SUBJECT TO LEGAL ACTION.



TMI Incorporated
 5350 Campbelle Run Road,
 Pittsburgh, PA 15205-9738

SCALE: 1:96

TMI Inc. Appr.: DATE

DRAWN BY: A. IODIZZO

TMI Inc. Appr.: DATE

TITLE: B410-12

DATE: 01.2003

PART NO.

REV.	DESCRIPTION	DATE	BY